

FEATURES

- The preferred pump frame in the pressure cleaning industry
- Forged brass manifold with an exclusive lifetime warranty
- Large-capacity, die-cast, anodized aluminum oil-bath crankcase
- Over-sized connecting rods for maximum life
- Heavy-duty tapered roller bearing.
- Solid ceramic plungers with continuously lubricated packings
- Unitized stainless steel inlet and discharge valves
- Available in left-handed "L" version



SPECIFICATIONS

Pump Model	TS1331		TS1711	T9211-N
Maximum Volume (GPM)	3.5	4.0	3.5 GPM	4.0 GPM
Max. Discharge Pressure (PSI)	2100	2000	2700 PSI	3000 PSI
Maximum Pump Speed (RPM)	1450	1750	1450 RPM	1750 RPM
Maximum Inlet Pressure	125 PSI			
Maximum Inlet Vacuum	9 ft. water (7.9 in. Hg)			
Bore	.787 in. / 20 mm			
Stroke	.394 in. / 10 mm			
Crankcase Oil Capacity	33.8 oz		40.6 oz..	
Maximum Fluid Temperature	165°F			
Inlet Port Thread	1/2-14 BSPP-F			
Discharge Port Thread	3/8-19 BSPP-F			
Shaft Diameter.	.945 in. / 24 mm			
Weight	32 lbs.			
Dimensions	12.2 x 9.2 x 6.9 in.			

N=Nickel-plated manifold

DIMENSIONAL DRAWING

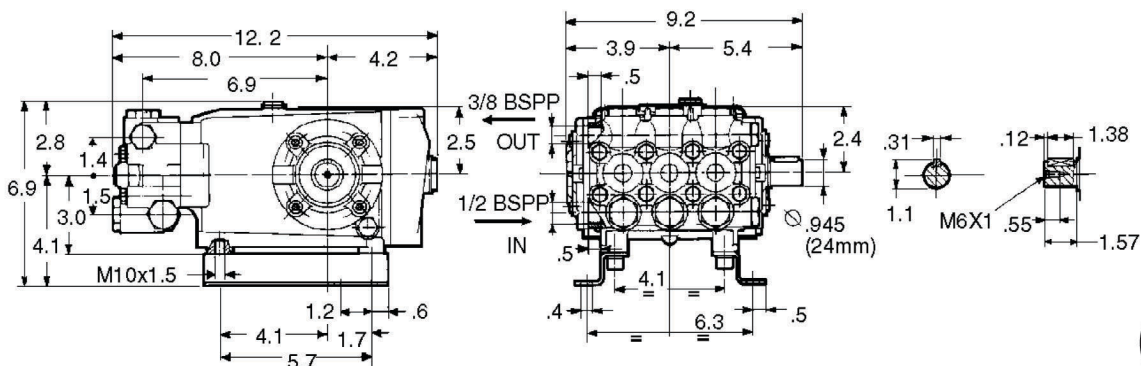

T Series 47 S – 20 mm x 10 mm

GENERAL PUMP

A member of the Interpump Group

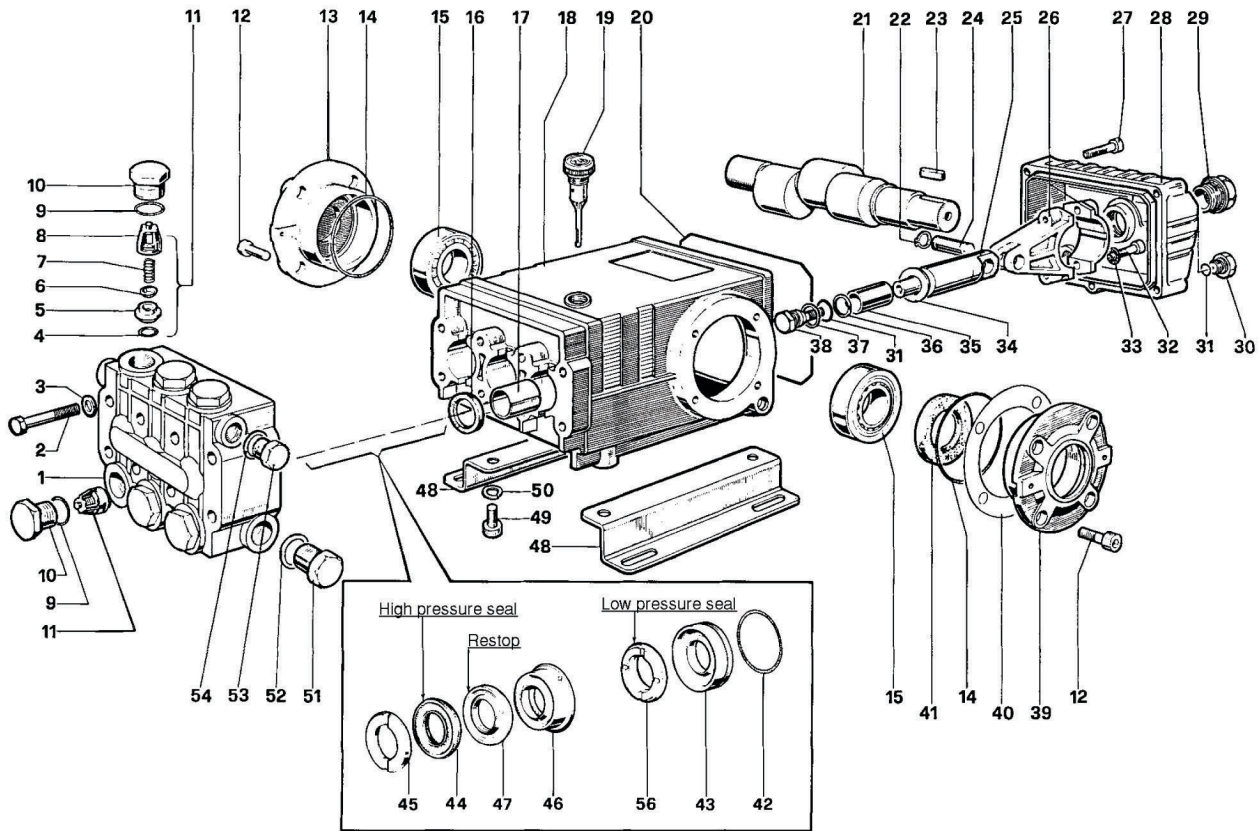

PARTS LIST

ITEM	PART NO.	DESCRIPTION	KIT NO.	QTY.	ITEM	PART NO.	DESCRIPTION	KIT NO.	QTY.	ITEM	PART NO.	DESCRIPTION	KIT NO.	QTY.
1.	47120841	Manifold		1	19.	98210600	Oil Dip Stick		1	37.	96728000	Washer	6	3
	47120941	Manifold, Nickel-Plated (T9211-N)		1	20.	90392200	O-Ring, Cover		1	38.	47219566	Screw, Plunger	6	3
2.	99320600	Screw, M8 x 70		8	21.	47021435	Crankshaft		1	39.	47150022	Cover, Crankcase		1
3.	96702000	Washer, M8.4		8	22.	90055700	Ring, Snap		6	40.	97567800	Shim		2
4.	90384100	O-Ring, .674 x .103	1	6	23.	91489000	Key		1	41.	90164800	Seal, Oil	3	1
5.	36200366	Seat, Valve	1	6	24.	97738000	Pin, Wrist		3	42.	90361600	O-Ring, 1.364 x .070	10, 28	3
6.	36200176	Plate, Valve	1	6	25.	47050554	Guide, Plunger		3	43.	47080570	Retainer, Packing	10, 28	3
7.	94737600	Spring	1	6	27.	99191200	Screw, M6 x 30		5	44.	90270500	Packing	28, 69	3
8.	36200251	Guide, Valve	1	6		99183700	Screw, M6 x 14 (TS1331)		5	45.	47100051	Ring, Head, M20	7, 28	3
9.	90384700	O-Ring, .797 x .103	4, 5	6	28.	47160122	Cover, Crankcase		1	46.	47216970	Intermed. Ring	28, 71	3
10.	98222000	Cap	4	6		47160022	Cover, Crankcase (TS1331)		1	47.	90270400	Restop Ring	28, 69, 71	3
	98222200	Cap, Ni-Plated (T9211-N)	5	6	29.	97596800	Oil Indicator		1	48.	47200074	Pump Feet		2
11.	36703201	Valve Assembly	1	6	30.	98204100	Cap		1	49.	99364400	Screw, M10 x 18		4
12.	99303900	Screw, M8 x 16		8	31.	90358500	O-Ring, .426 x .070	6	4	50.	96710600	Washer, M10.2		4
13.	47150122	Cover, Crankcase		1	32.	99309900	Screw, M8 x 35		6	51.	98217600	Cap		1
14.	90391300	O-Ring, 2.675 x .103		2	33.	96701400	Washer, M8.4		6	52.	96751400	Washer, M21.5		1
15.	640047	Bearing, Roller		2	34.	96728600	Washer, M14	6	3	53.	98210000	Cap		1
16.	90162500	Seal, Oil	2	3	35.	47040409	Plunger, (20 mm)		3	54.	96738000	Washer, M17.5		1
17.	90912600	Bushing		3	36.	90506700	Ring, Back-up	6	3	56.	90271000	Seal, Low Press., 20mm	28, 69	3
18.	47010522	Crankcase		1										

REPAIR KITS

KIT NO.	1	2	3	4	5	6	7	10	28	69	71
ITEM NO.s INCLUDED IN KIT	4, 5 6, 7, 8 (11)	16	41	9, 10	9, 10	31, 34, 36, 37, 38	45	42, 43	42, 43, 44, 45, 46, 47, 56	44, 47, 56	46, 47
NUMBER OF ASSEMBLIES IN KIT	6	3	2	6	6	3	6	3	1	3	3
NUMBER OF CYLINDERS KIT WILL SERVICE	3	3	-	3	3	3	3	3	1	3	3

TORQUE SPECS*

Position	Ft.-lbs.
2	22.1
10	73.7
12	14.7
27	7.3
29	13.2
30	14.7
32	14.7
38	14.7
49	29.4
51	29.4
53	29.4

*Decrease torque by 20% if threads are lubricated.



YGR1000/1125

Gear Reducer

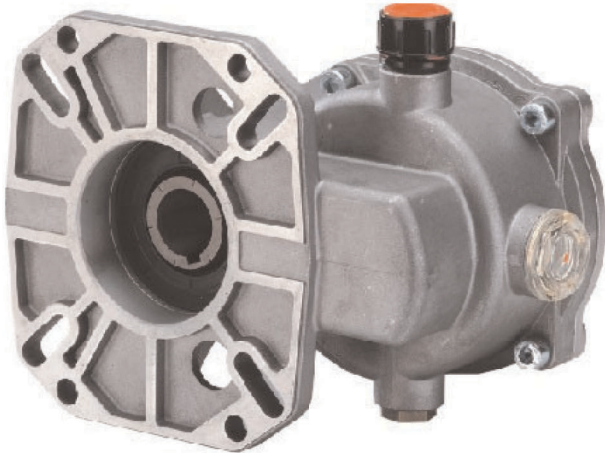

FEATURES

- Compact and lightweight
- Hardened steel helical gears for quiet operation
- Oil bath lubrication
- Dual bearing design for extended life
- J609a Flange mounts to most gasoline engines

SPECIFICATIONS

Part Number	YGR1000	YGR1000P	YGR1125	YGR1125P
Drive Ratio	2.176:1			
Horsepower	11-18	18-24	11-18	18-24
Input (motor) Shaft Ø"	1.0" / 25.4 mm		1.125" / 28.6 mm	
Output (pump) Shaft Ø"	24 mm			
Motor Flange (SAE)	J609a			
Pump Flange	Fits 47, 47SS, and 66 Series General Pump			
Oil Grade	SAE90 Gear Lube			
Oil Capacity	10 oz			
Weight	5.8 lbs			

DIMENSIONAL DRAWING

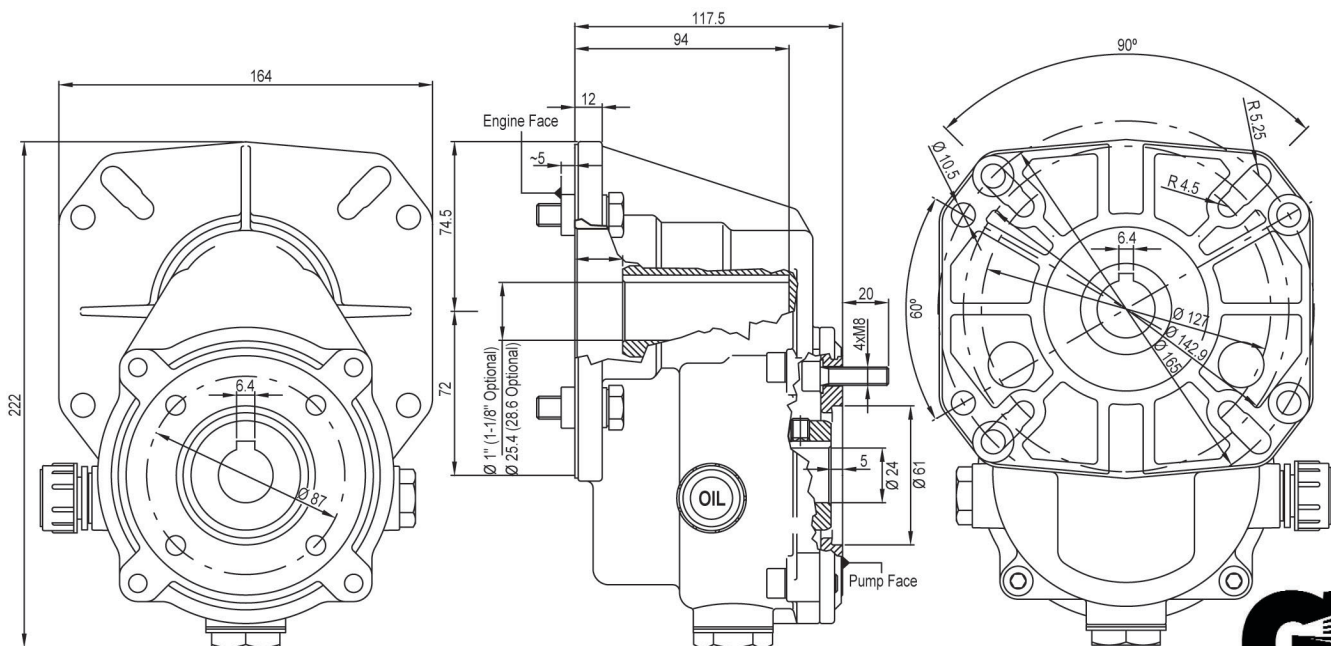

TT Series 51, EBF

GENERAL PUMP *A member of the Interpump Group*

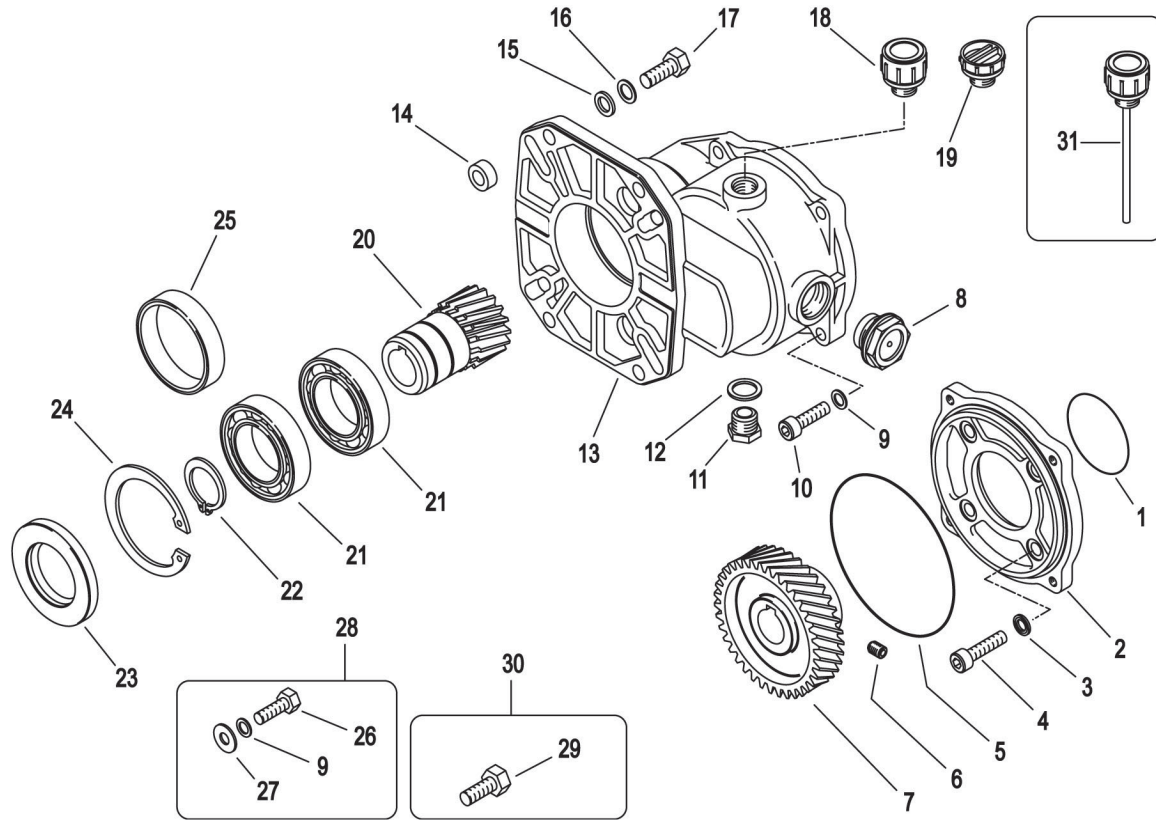

PARTS LIST

Item	Part Number	Description	Qty	Item	Part Number	Description	Qty
1	Y10321056	O-ring	1	18	Y15372600	Oil plug+seal	1
2	Y50000244	Flange	1	19	Y15372500	3/8" plas.cap	1
3	Y14409800	8 mm sealing washer	4	20	Y50000621	1" gear	1
4	Y16195831	M8 x 30 mm screw	4		Y50000721	1-1/8" gear	1
5	Y10321111	O-ring	1	21	Y11444068	Bearing (standard)	2
6	Y16222300	M8 x 10mm screw	1		Y11444168	Bearing ("P" models)	2
7	Y50000365	37 gear	1	22	Y10104000	Elas.ring 40 mm	1
8	Y15373400	Oil plug	1	23	Y10204072	40 mm seal	1
9	Y14365200	8.4 mm washer	8	24	Y10107200	Elas.ring 72 mm	1
10	Y16195826	M8 x 25 mm screw	4	25	Y50010161	68 mm spacer	1
11	Y60002831	3/8 Bsp plug	1	26	Y16200900	5/16" x 1" screw	4
12	Y14404200	Washer 16 x 22 mm	1	27	Y14357200	Washer 8.4 x 20 mm	4
13	Y50000144	Al.housing	1	28	Y50001024	Kit 5/16" D.127mm	1
14	Y50000831	Spacer	4	29	Y16203500	M 10 screw	4
15	Y14379800	10 x 17 mm washer	4	30	Y50001124	Kit d.135mm M10	1
16	Y14365300	10.5 mm washer	4	31	Y15372800	Oil plug	1
17	Y16201000	3/8" x 1-1/4"	4				